

TN-22-16-001 R1 January 5, 2024		Tesla, Inc. Technical Note
Model:	Vehicle System:	Region:
Model Y Structural Pack	16 - Battery System	All

Inspect the Model Y Structural HV Battery for Underside Damage

Tech Notes are announcements that help to communicate and track new information about Tesla Service concerns. Such concerns may or may not be VIN specific. These instructions assume knowledge of motor vehicle and high voltage electrical component repairs and should only be executed by trained professionals. Tesla assumes no liability for injury or property damage due to a failure to properly follow these instructions or for repairs attempted by unqualified individuals.

This Tech Note supersedes TN-22-16-001, dated June 8, 2022. This new revision, R1, updates the contact information for European Body Shops. Each content change is marked by a vertical line in the left margin. Discard the previous version and replace it with this one.

NOTE: This document is only applicable for Model Y vehicles equipped with the structural High Voltage (HV) battery. For non-structural Model Y vehicles, refer to [TN-18-16-001](#). To determine if a vehicle has a structural HV battery, use Garage and see if the “structural_pack” tag is present underneath the VIN (Figure 1).

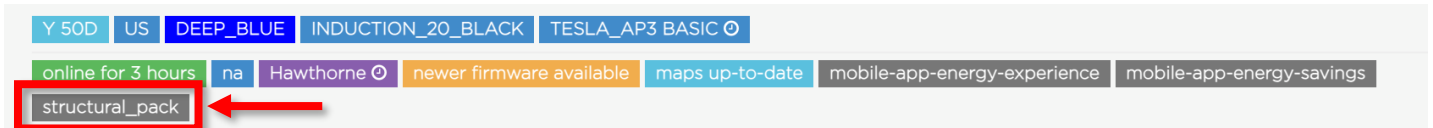

Figure 1

Whenever the vehicle is raised, or if the customer has indicated possible damage, the underside of the vehicle, including the HV battery, should be visually inspected for damage. HV battery damage may include:

- Dents, holes, cracks, or tears
- Corrosion or moisture accumulation
- Evidence of a previous thermal event, such as smoke residue, discoloration, deformation, melted seals, metallic platter, or abnormal odor
- Rupture or disassembly
- Coolant or electrolyte leakage

NOTE: If a vehicle is brought into a Body Shop with visible damage to the bottom of the HV battery, the Body Shop should contact Tesla:

- **In Europe, Middle East, and Africa:** Contact EMEAbodyrepairRTS@tesla.com.
- **All other regions:** Contact your local Tesla Service Center.

The Body Shop should not try to repair the HV battery damage. Only Tesla Service Centers should try to repair the damaged HV battery.

⚠ WARNING: If the HV battery enclosure is compromised with a **visible open hole, crack, or tear** (Figures 2 and 3), the Service Center doesn't need to continue further with this document and should recommend the customer replace the HV battery to meet Tesla's standards of quality and safety. Meanwhile, the HV battery might be compromised and needs to be taken care of diligently; refer to Toolbox article [29715](#) for assessing a compromised HV battery.



Figure 2 – Visible open hole



Figure 3 – Visible open crack

☰ NOTE: If at any point during the inspection the damage requires a HV battery replacement, advise the customer that the HV battery requires replacement to meet Tesla's standards of quality and safety. Tesla does not recommend driving the vehicle until the HV battery is replaced. Since the new HV battery replacement is not covered under the vehicle warranty, the Service Center should recommend that the customer replace the HV battery and provide the customer a price quote for the HV battery replacement. The warranty does not cover HV battery damage caused by an external impact.

☰ NOTE: If a replacement HV battery is recommended for any out of warranty repair and the customer declines the repair, refer to Toolbox article [6101300](#) for the appropriate next actions.

⚠ WARNING: Failure to follow all HV safety precautions, including the use of personal protective equipment, when working on or around HV components may result in serious injury or property damage. Only technicians who have completed Tesla's Mechanical, Electrical, and Trim training course should diagnose, repair, or replace HV components. In addition, all repair and operating instructions should be reviewed and understood before working on Tesla vehicles or associated repair equipment.

⚠ WARNING: An HV battery poses a significant high voltage and electrocution risk if the outer enclosure or safety circuits have been compromised or have been significantly damaged. Proper Personal Protective Equipment (PPE) and insulating HV gloves with a minimum rating of class 0 (1000V) must be worn any time a high voltage component is handled. Refer to [TN-15-92-003](#), "High Voltage Awareness Care Points" for additional safety information.

⚠ WARNING: If the HV battery or vehicle displays signs of escaping gases, smoke, flames, excessive heat, sparks, or arcing, contact the local emergency department and refer to the Emergency Response Guide, available at <http://www.tesla.com/firstresponders> and/or [TN-13-16-007](#), "Lithium-Ion Battery Emergency Response Guide". Gases or smoke exiting a lithium-ion HV battery are likely flammable and could ignite at any time.

⚠ WARNING: Avoid contact with gases escaping from the HV battery. Vented gases might irritate the eyes, skin, and throat. Vent gas temperatures can exceed 600°C (1,110°F). Contact with hot gases can cause burns.

⚠ WARNING:

- Inspect or repair a vehicle that has an unstable battery outdoors or within easy access to the outdoors.
- If an HV battery has been determined to have a coolant leak, do not pressurize the cooling system.
- Store damaged HV batteries at least 15 m (50 ft) away from flammable materials, structures, other vehicles, and other HV batteries.
- Avoid storing standalone HV batteries below -20°C (-4°F).
- Avoid storing standalone HV batteries for over 10 days above 35°C (95°F).
- Do not charge or discharge a standalone HV battery below 0°C (32°F).
- Do not store standalone HV batteries for over 30 days at full state of charge (SOC) or completely discharged.
- Do not charge a damaged or potentially unstable HV battery.
- Do not weld near HV batteries.

Structural HV Battery Assembly Underside

The underside of the structural HV battery assembly has several key components (Figure 4).

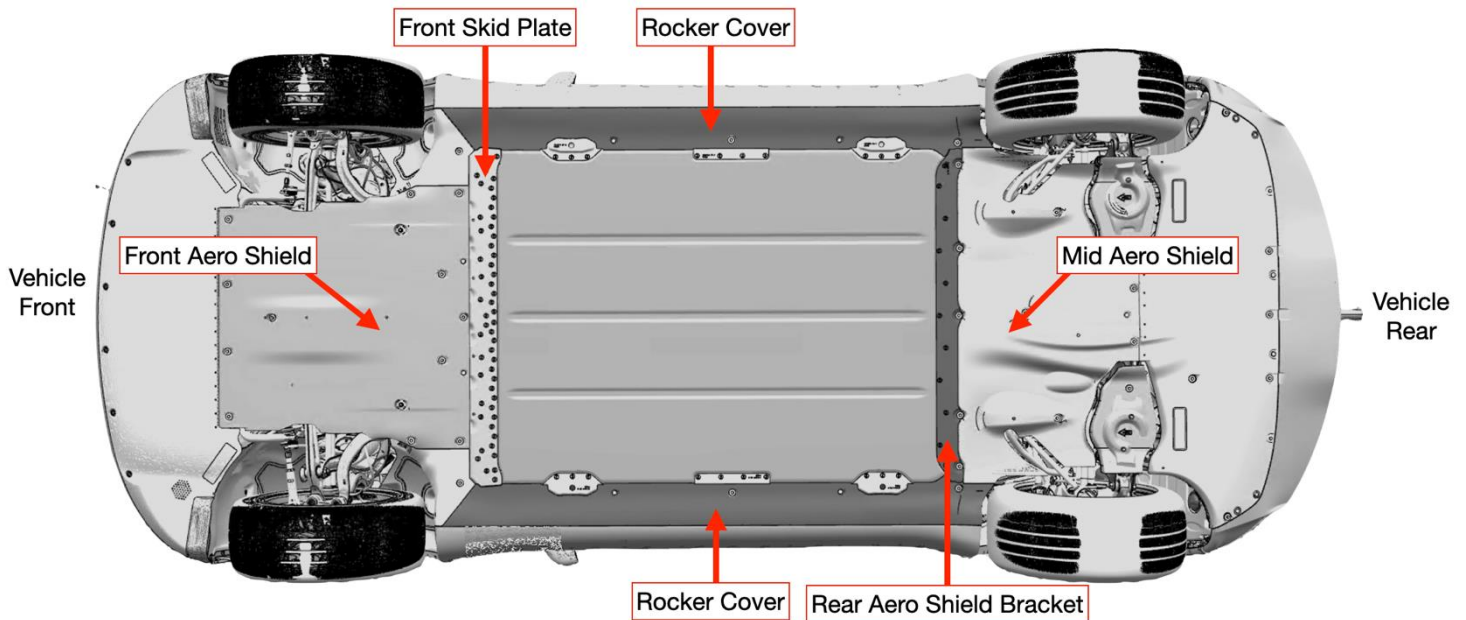

Figure 4 – Structural HV battery assembly key components

The bottom of the structural HV battery assembly can be divided into a grid to make it easier to track and report damage (Figure 5).

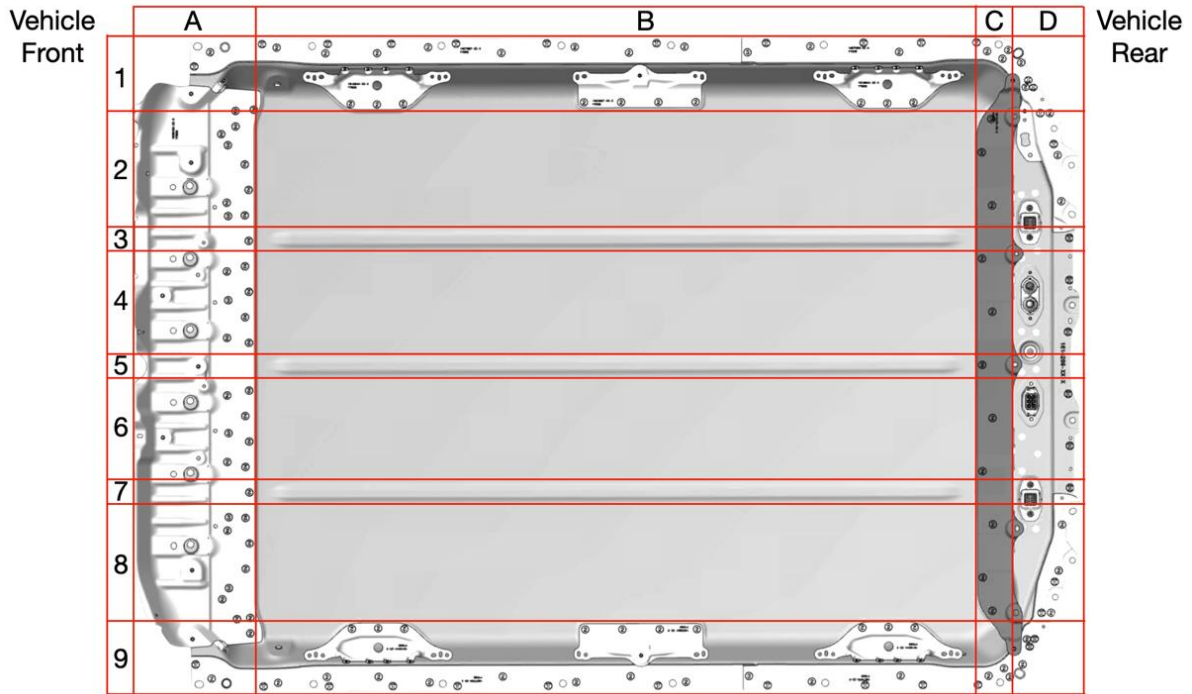
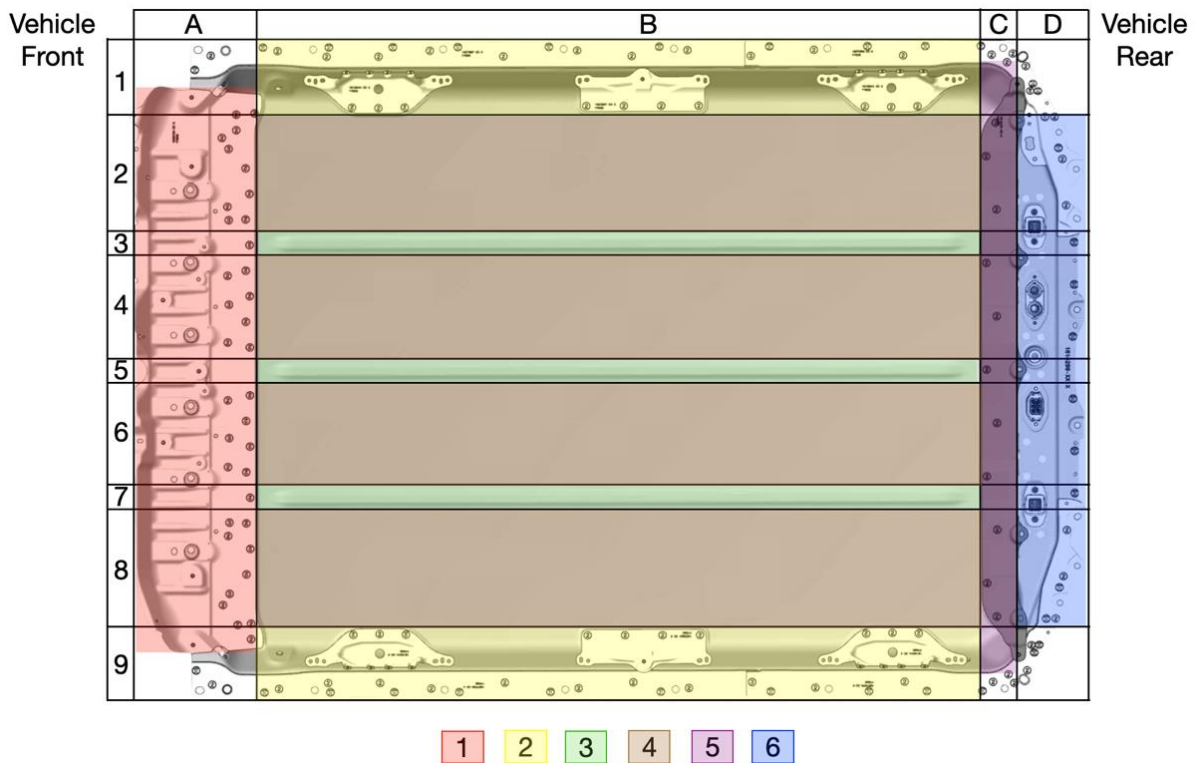

Figure 5 – Structural HV battery underside grid layout

The grid locations for the underside component / zone of the structural HV battery assembly (Figure 6).



	HV Battery Component / Zone	Grid Locations
1	Front Skid Plate	A1 – A9
2	Side Zone	B1, B9
3	Array Barrier Zone	B3, B5, B7
4	Array Baseplate Zone	B2, B4, B6, B8
5	Rear Aero Shield Bracket	C1 – C9
6	Connector / Rear Zone	D2 – D8

Figure 6 – HV battery underside grid

The front and rear component locations of the structural HV battery assembly (Figure 7).

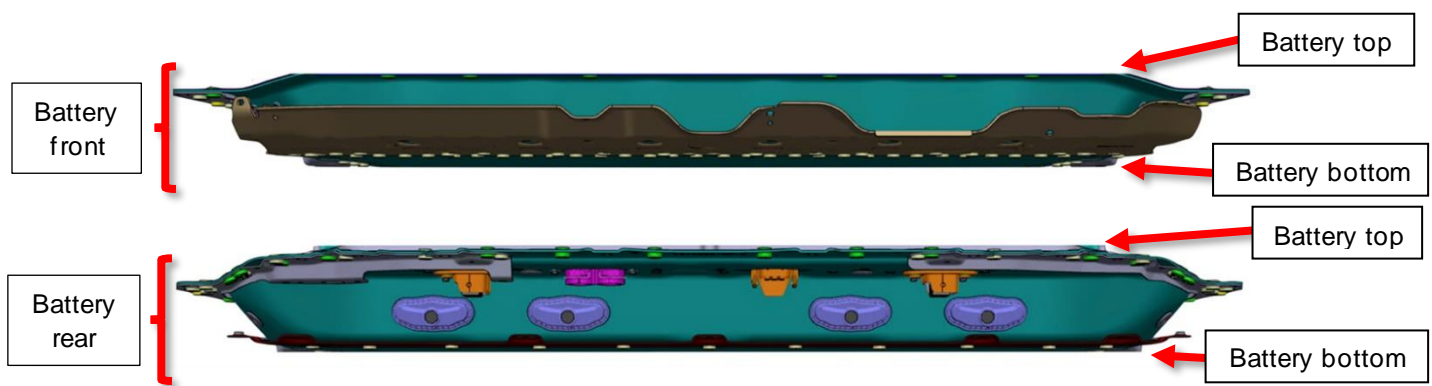

	HV Battery Component
1	Front skid plate
2	Baseplate
3	Rear aero shield bracket
4	Thermal vent
5	Coolant passthrough
6	HV connector header

Figure 7 – Structural HV battery front and rear

If there is noticeable damage to the bottom of the HV battery assembly:

1. Create a Toolbox session with Toolbox article [37566](#) marked as an issue.
2. Add the comment “@NACompromisedBattery”, “@EUCompromisedBattery”, or “@APACCompromisedBattery”, depending on your region,” to add HV battery inspection engineers as watchers.
3. Collect the following information and upload it to the session:
 - a. Several pictures of the damage, taken with a high-resolution camera: If there isn't a visible open hole, crack, or tear, measure the depth of the HV battery enclosure damage (Figure 8) **while wearing proper PPE**. If the damage is not obvious, take an overall picture of the HV battery, with pointers to the damaged area(s).

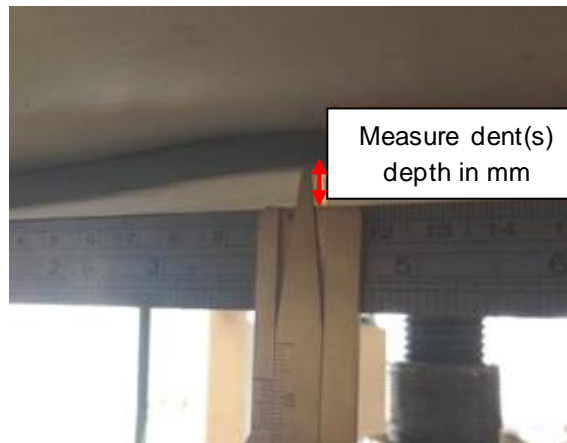

Figure 8 – Measuring the depth of enclosure damage

- b. Information from the customer about the incident that may have caused the damage, if available.
 - c. The location of the damage according to the specific zone (Figure 6).
4. Perform the appropriate repair according to the corresponding zone below.

Front Skid Plate

The front skid plate is located at the front of the HV battery (Figure 9):

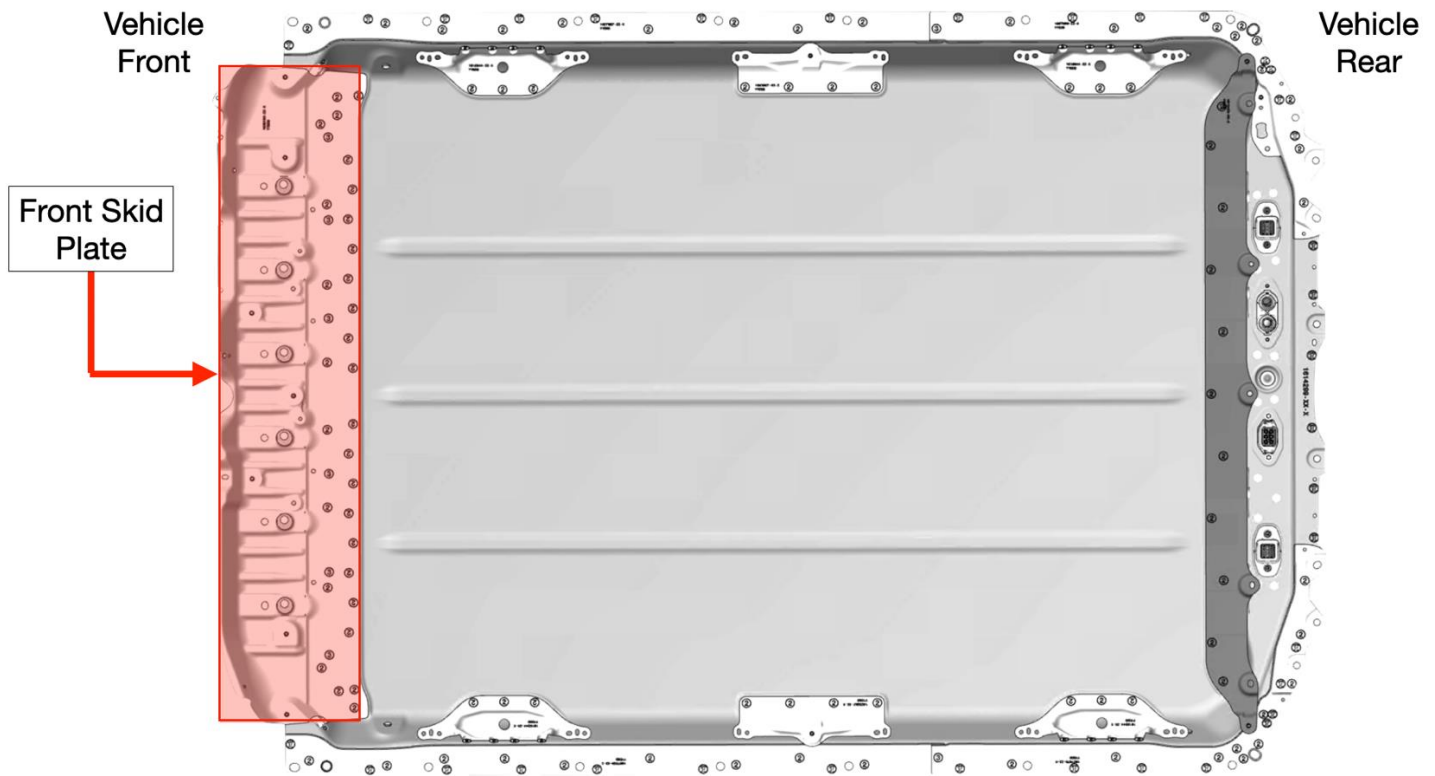

Figure 9 – Front skid plate location

To inspect the front skid plate for damage:

1. Remove the front aero shield (refer to Service Manual procedure [12030112](#)).
2. Visually inspect the front skid plate for tears, dents, or breaches.
3. Inspect the HV cables, coolant hoses, baseplate, and passthroughs above the front skid plate.
4. If there is damage to the front of the enclosure above the front skid plate, see "[Front Zone](#)" section below.
5. If there is damage that extends onto the array baseplate, array barrier, or side zone, go to those specific sections below.



NOTE: The bolts that join the front aero shield and front skid plate are prone to shearing in the event of front skid plate damage.

Suggest repair to customer:

- Deburr the area with a hand deburring tool to remove the sharp edges if sharp edges are found.
- Re-tap the fastener hole if a fastener hole is damaged and the fastener cannot withstand full torque.
- Recommend replacement of the:
 - Fastener if the fastener is damaged or stripped.
 - HV cables if the HV cables are damaged above the front skid plate.
 - Coolant hose if the coolant hose is damaged.
 - Front aero shield if the aero shield is damaged or cannot be secured properly.
- Recommend HV battery replacement if:
 - The front skid plate, or part of the front skid plate, is bent beyond repair, detached, or not covering the baseplate.
 - If the coolant passthrough is damaged.
 - The HV battery enclosure fails leak test due to impact.
 - The HV battery enclosure has low isolation due to impact.

⚠ WARNING: Do not drill new holes in any part of the HV battery, skid plates, or aero shields.

Front Zone

The front zone includes everything located at the front of the HV battery except the front skid plate (Figure 10).

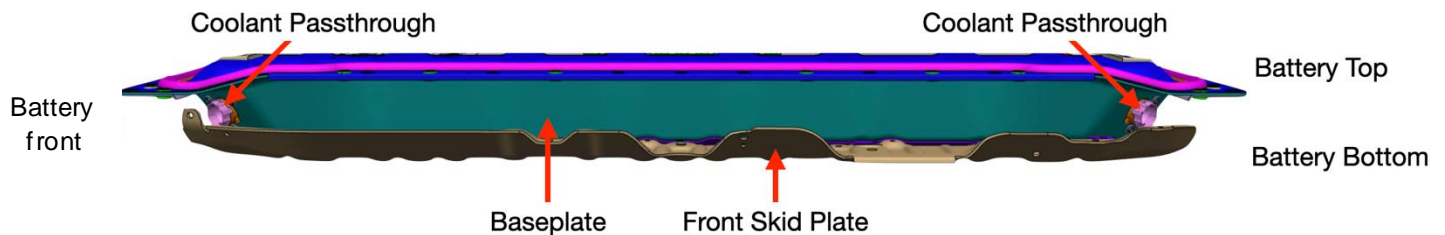

Figure 10 – Front zone

Suggest repair to customer:

- Deburr the area with a hand deburring tool to remove the sharp edges if sharp edges are found.
- Recommend replacement of the:
 - HV cables if the HV cables are damaged above the front skid plate.
 - Coolant hose if a coolant hose is damaged.
 - Front aero shield if the aero shield is damaged.
- Recommend HV battery replacement if:
 - A coolant passthrough is damaged.
 - The HV battery enclosure fails leak test due to impact.
 - The HV battery enclosure has low isolation due to impact.

Side Zones

The HV battery has two side zones (Figure 11). For each side zone, there is a front and rear jack point, along with multiple rocker panel mounts which hold the rocker panels in place to protect the sides of the HV battery enclosure. The side zone includes both sides of the HV battery enclosure itself when the side rocker covers are removed.

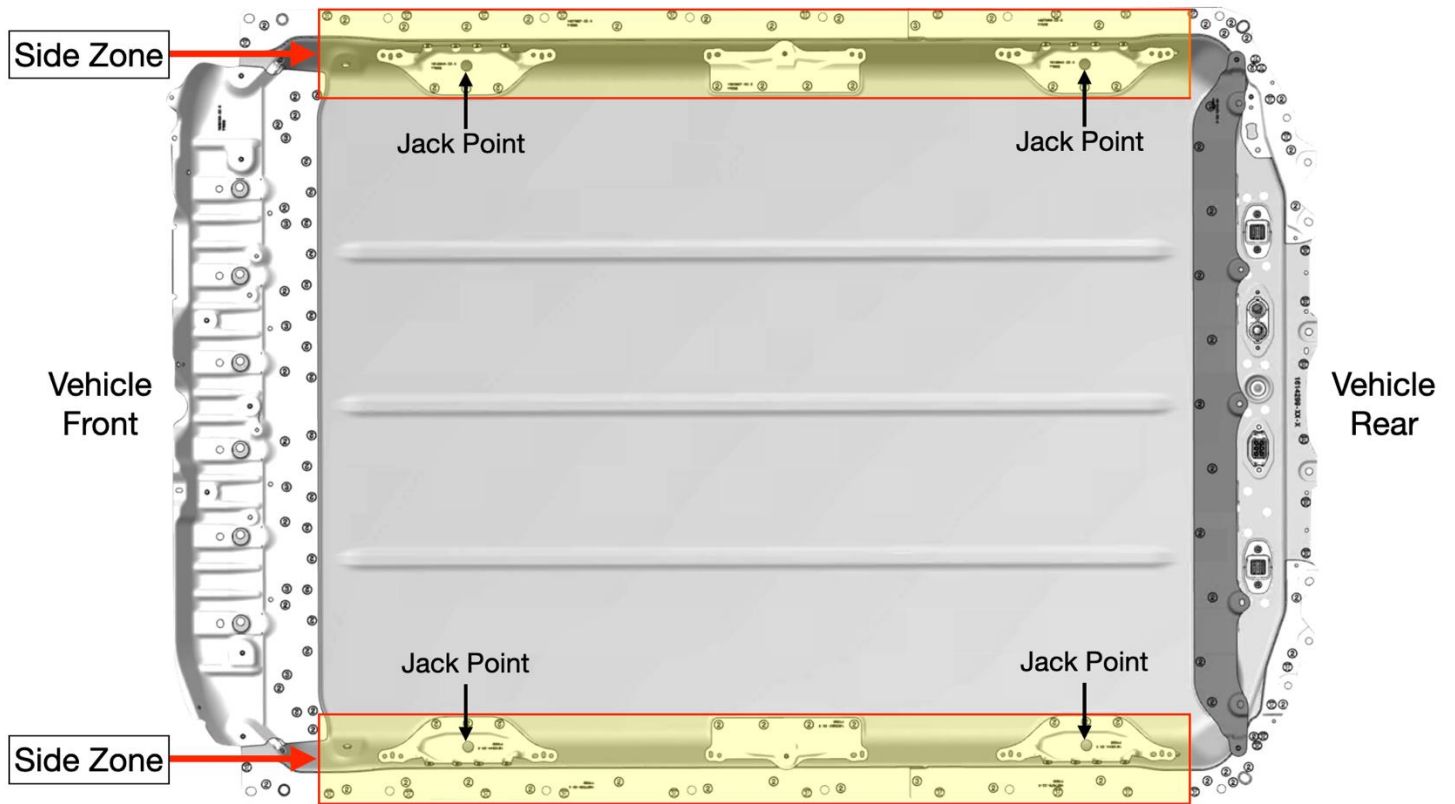

Figure 11 – Side zones

While the HV battery is still installed in the vehicle:

1. Visually inspect the side rocker covers (Figure 12).

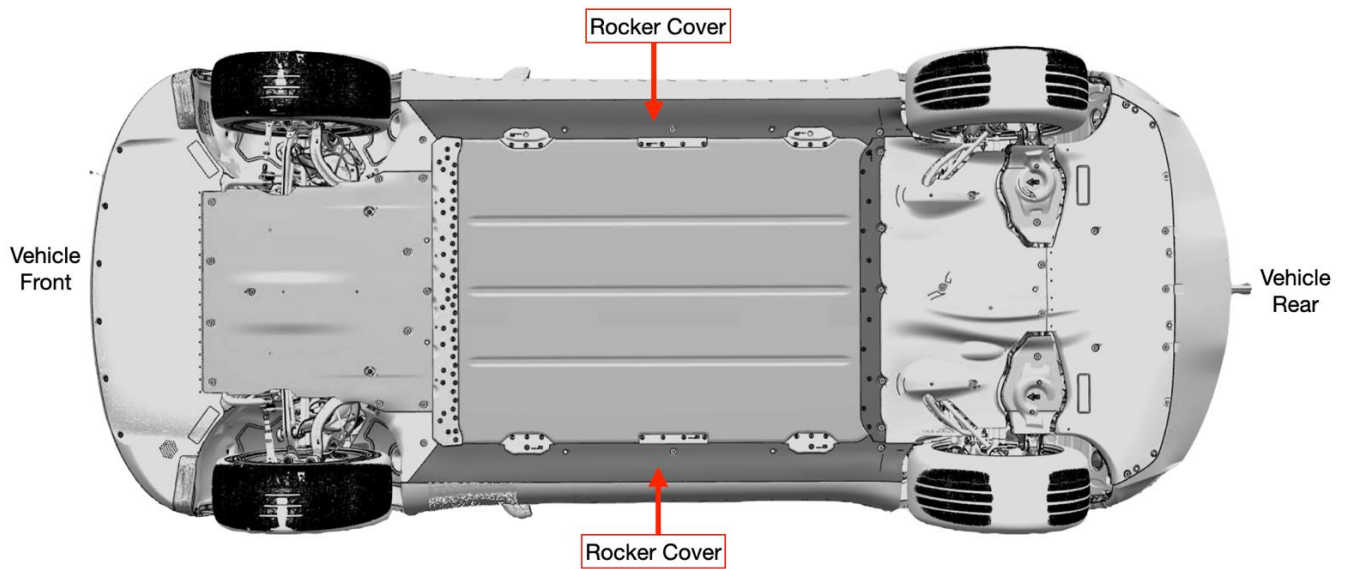

Figure 12 – Side rocker covers

2. Remove the rocker cover(s) and inspect the HV cables and/or coolant hoses thoroughly (Figures 13 and 14).

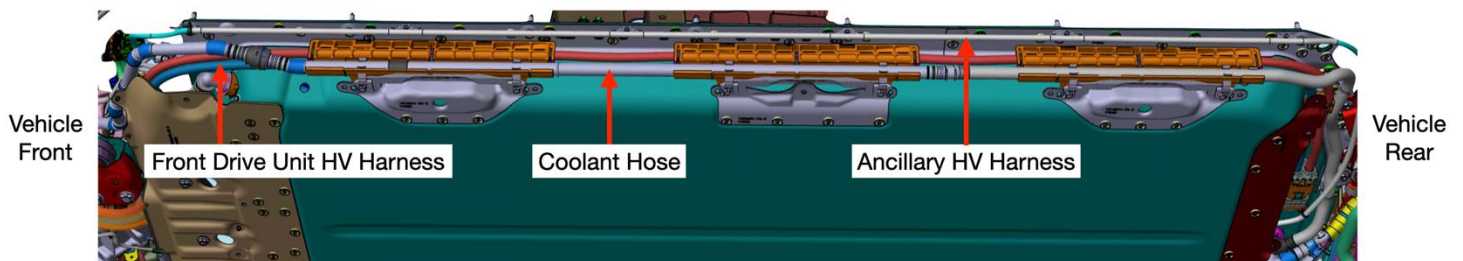

Figure 13 – Left side of HV battery

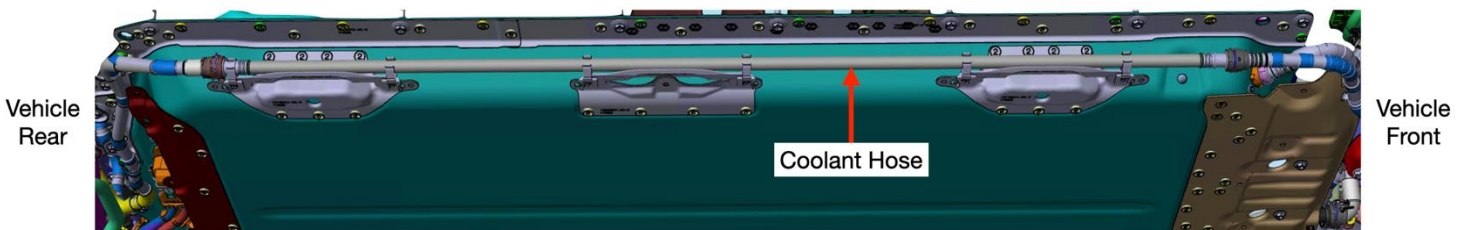

Figure 14 – Right side of HV battery

Suggest repair to customer:

- Deburr the area with a hand deburring tool to remove the sharp edges if sharp edges are found.
- Re-tap the fastener hole if a fastener hole is damaged and the fastener cannot withstand full torque.
- Recommend replacement of the:
 - Fastener if the fastener is damaged or stripped.
 - HV cables if the HV cables are damaged.
 - Coolant hose if the coolant hose is damaged.
 - Rocker cover if the rocker cover, or part of the cover is detached from the HV battery and cannot be secured properly.
- Recommend HV battery replacement if:
 - A jack point has extensive damage where it cannot be used to safely lift the vehicle.
 - The HV battery enclosure fails leak test due to impact.
 - The HV battery enclosure has low isolation due to impact.

Array Barrier Zones

The array barriers are located between the 4 battery arrays and act as a separator for each array (Figure 15). The array barriers start at the rear of the front skid plate and extend to the front edge of the rear aero shield bracket.

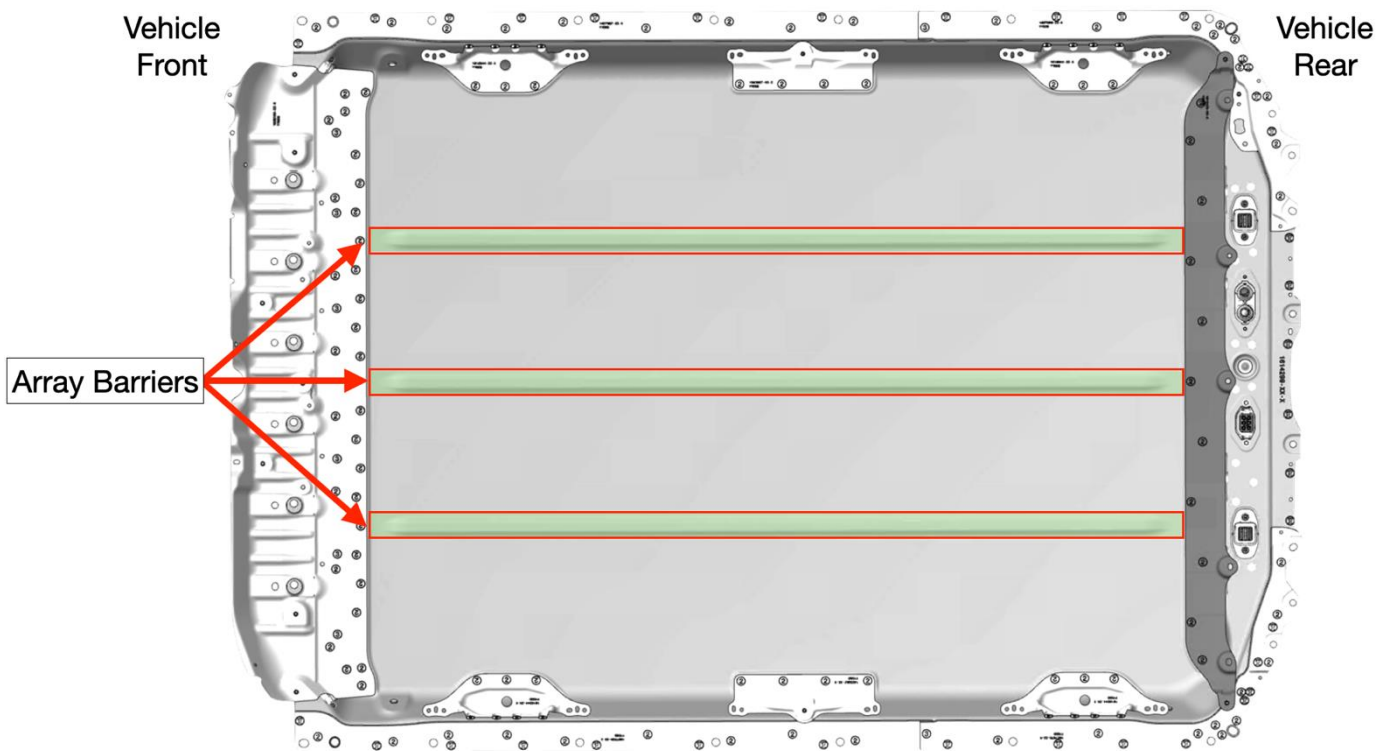

Figure 15 – Array barriers

NOTE: If any damage extends onto the baseplate, go to the baseplate section below for that specific location.

Suggest repair to customer:

- Deburr the area with a hand deburring tool to remove the sharp edges if sharp edges are found.
- Recommend HV battery replacement if:
 - The HV battery enclosure fails leak test due to impact.
 - The HV battery enclosure has low isolation due to impact.

NOTE: There is no depth measurement threshold for the array barrier zones since no cells are within these specific zones.

Array Baseplate Zone

The array baseplate zones covers most of the underside of the HV battery and serves as a base for the battery arrays (Figure 16). The array baseplate zones start at rear of the front skid plate and extends to the front edge of the rear aero shield bracket.

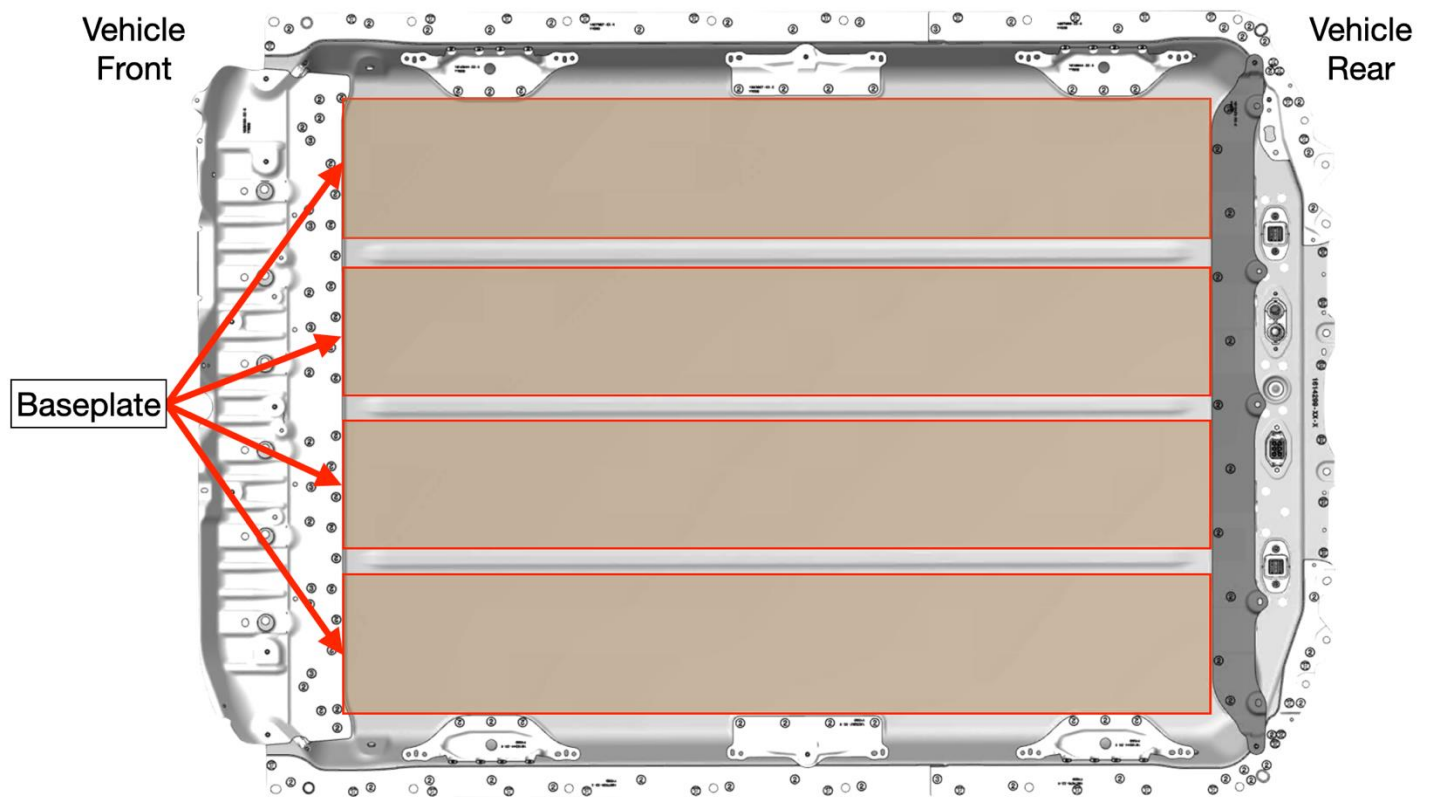

Figure 16 – Array baseplate

When the baseplate is damaged, follow the steps below:

Suggest repair to customer:

- Deburr the area with a hand deburring tool to remove the sharp edges if sharp edges are found.
- Recommend HV battery replacement if:
 - A dent or deepest point of gouge is **5 mm** or more in depth (Figures 17 and 18) within the array baseplate zone.

NOTE: Depth measurements should only be taken within the baseplate zones, **NOT** the array barrier zone. If a dent overlaps into an array barrier zone, measure the largest depth within just the baseplate zone, even though the deepest depth may be within the array barrier zone.

- The HV battery enclosure fails leak test due to impact.
- The HV battery enclosure has low isolation due to impact.

NOTE: If the damage extends onto a different zone, see that specific zone if a new HV battery isn't already needed to be recommended to the customer.

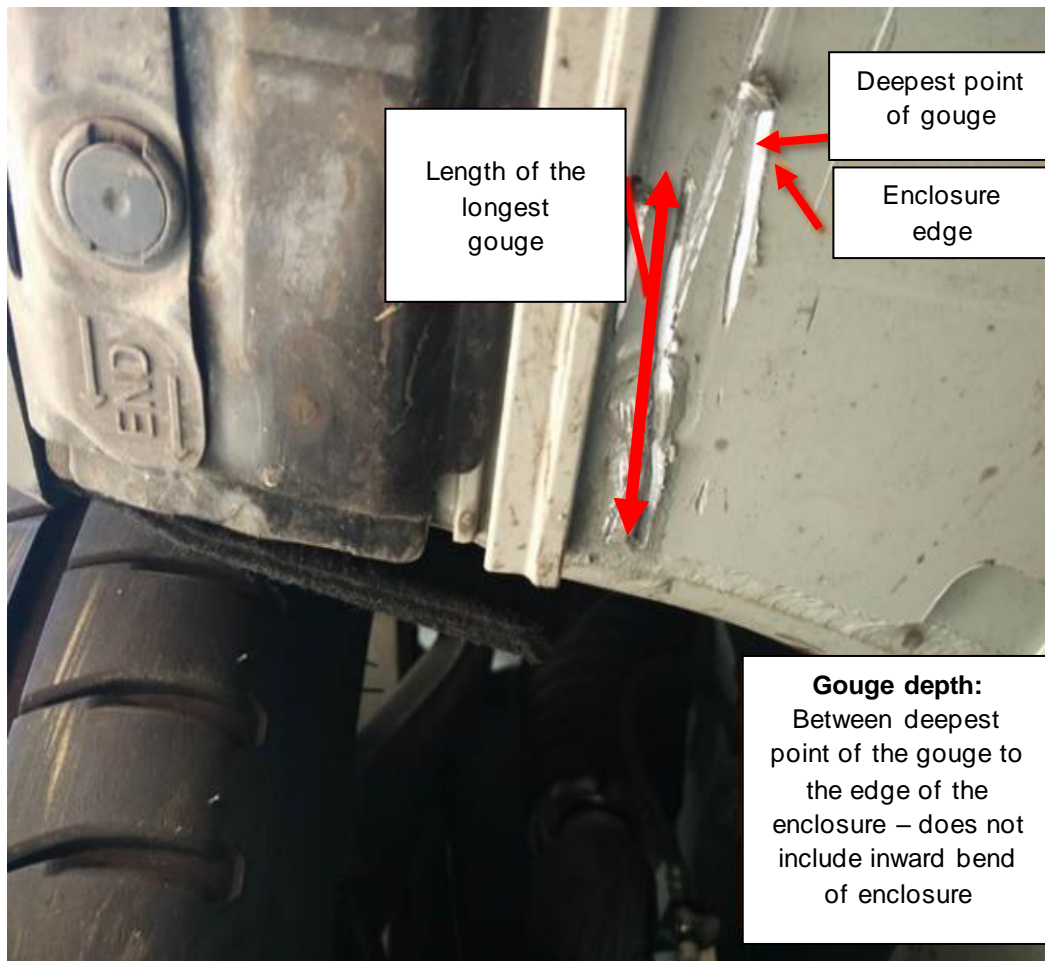

Figure 17 – Gouges in the baseplate

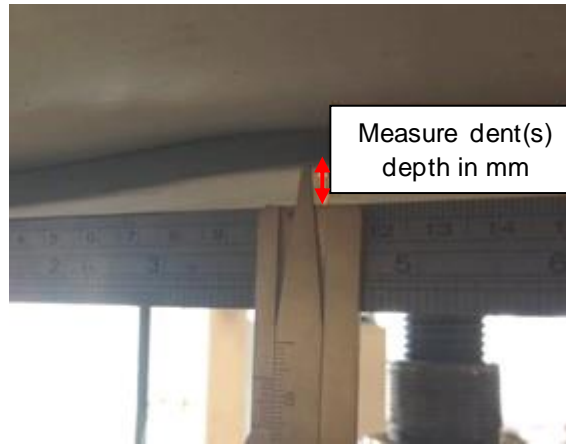

Figure 18 – Dents in the baseplate

Rear Aero Shield Bracket

The rear aero shield bracket is located at the rear of the HV battery (Figure 19):

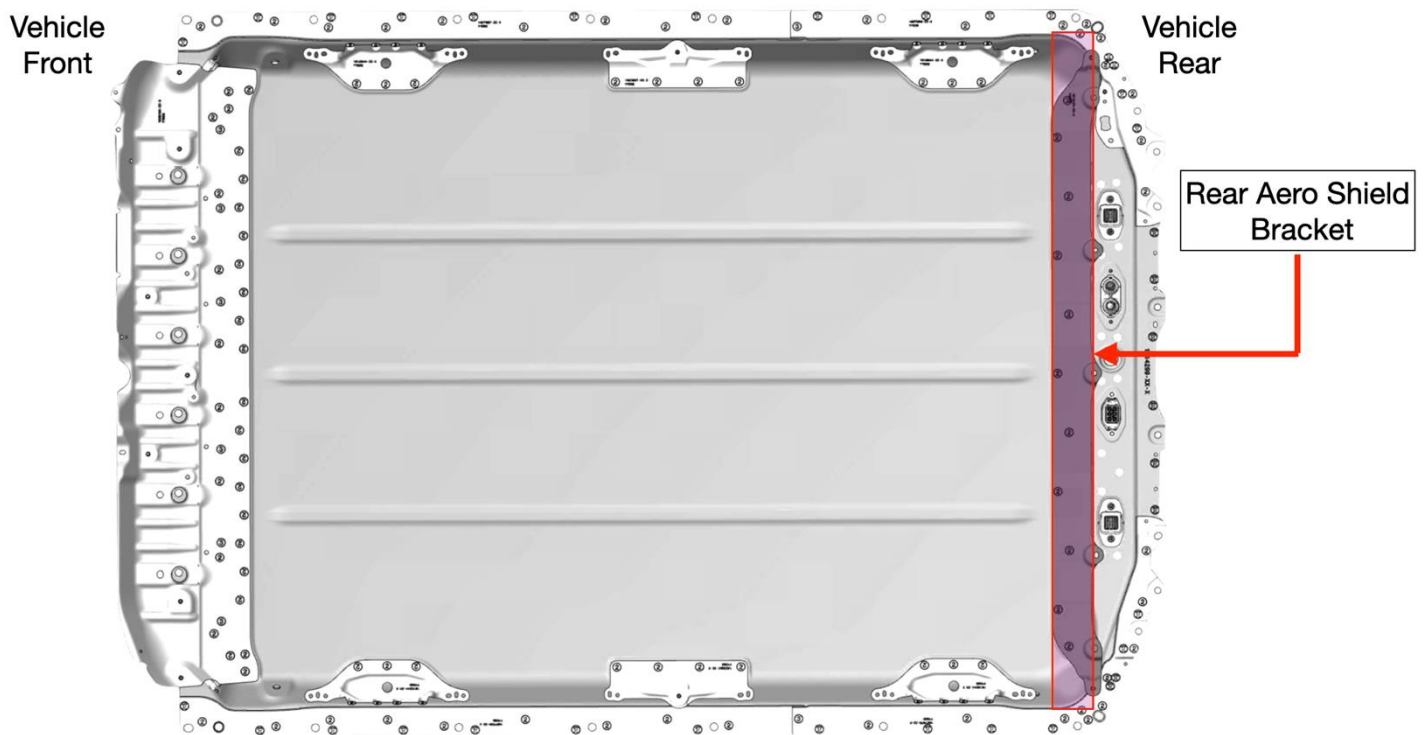

Figure 19 – Rear aero shield bracket

To inspect the rear aero shield bracket for damage:

1. Remove the mid aero shield (refer to Service Manual procedure [12030502](#)).
2. Remove and assess damage to components at the rear of the HV battery such as HV harness cables, passthroughs, baseplate, fasteners, etc. If any components at the rear of the HV battery are damaged or missing, see "[Connector / Rear Zone](#)" section below.

Suggest repair to customer:

- Deburr the area with a hand deburring tool to remove the sharp edges if sharp edges are found.
- Recommend replacement of the:
 - o Fastener if the fastener attaching the mid aero shield and rear aero shield bracket is damaged or stripped.
 - o Mid aero shield if the aero shield is damaged or cannot be secured properly.
- Recommend HV battery replacement if:
 - o The rear aero shield bracket, or part of the bracket, is bent beyond repair, detached, or not covering the baseplate.
 - o The HV battery enclosure fails leak test due to impact.
 - o The HV battery enclosure has low isolation due to impact.

Connector / Rear Zone

The connector / rear zone is located at the rear of the HV battery and above the rear aero shield bracket (Figure 20), and includes of all the major HV battery connection points and vents.

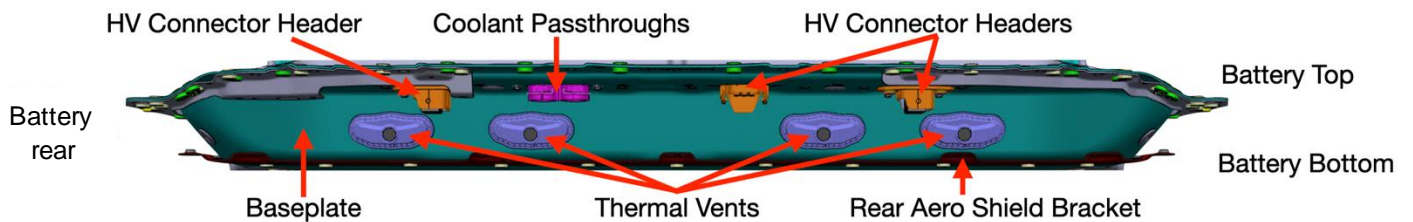

Figure 20 – Connector / rear zone

Suggest repair to customer:

- Deburr the area with a hand deburring tool to remove the sharp edges if sharp edges are found.
- Recommend replacement of the:
 - Mid aero shield if the aero shield is damaged or cannot be secured properly.
 - HV cables if the HV cables are damaged above the front skid plate.
 - Coolant hose if a coolant hose is damaged.
 - HV connector header if the header is damaged.
 - Coolant passthrough if the passthrough is damaged.
- Recommend HV battery replacement if:
 - A thermal vent is damaged or missing.
 - The rear aero shield bracket, or part of the bracket, is bent beyond repair, detached, or not covering the baseplate.
 - The HV battery enclosure fails leak test due to impact.
 - The HV battery enclosure has low isolation due to impact.

For feedback on the accuracy of this document, email ServiceBulletinFeedback@tesla.com.